

10/2549/EIS – Lambs Hill Wind Farm
Appendix reference 1
Site location plan

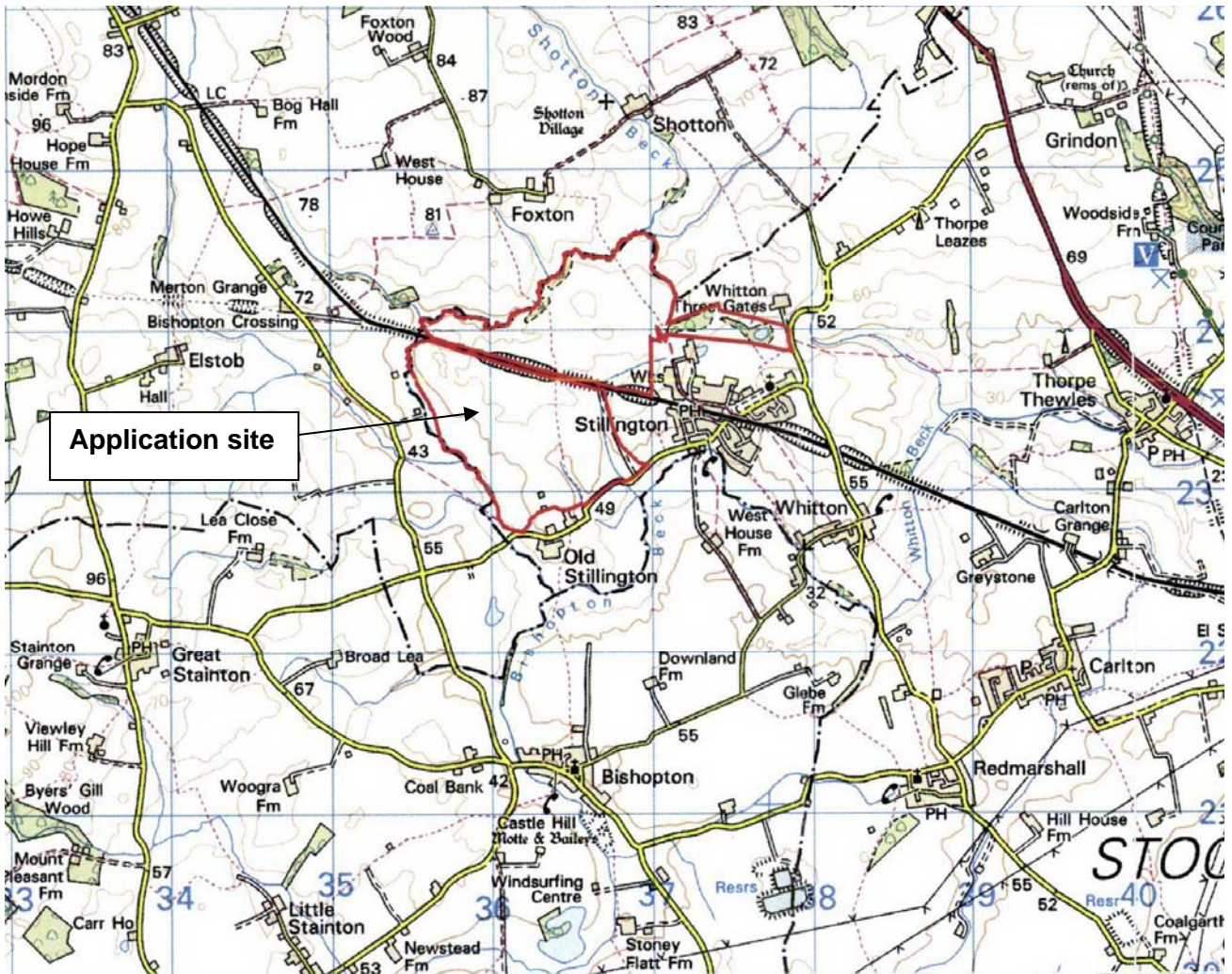

10/2549/EIS – Lambs Hill Wind Farm
 Appendix reference 2
 Site Layout Plan

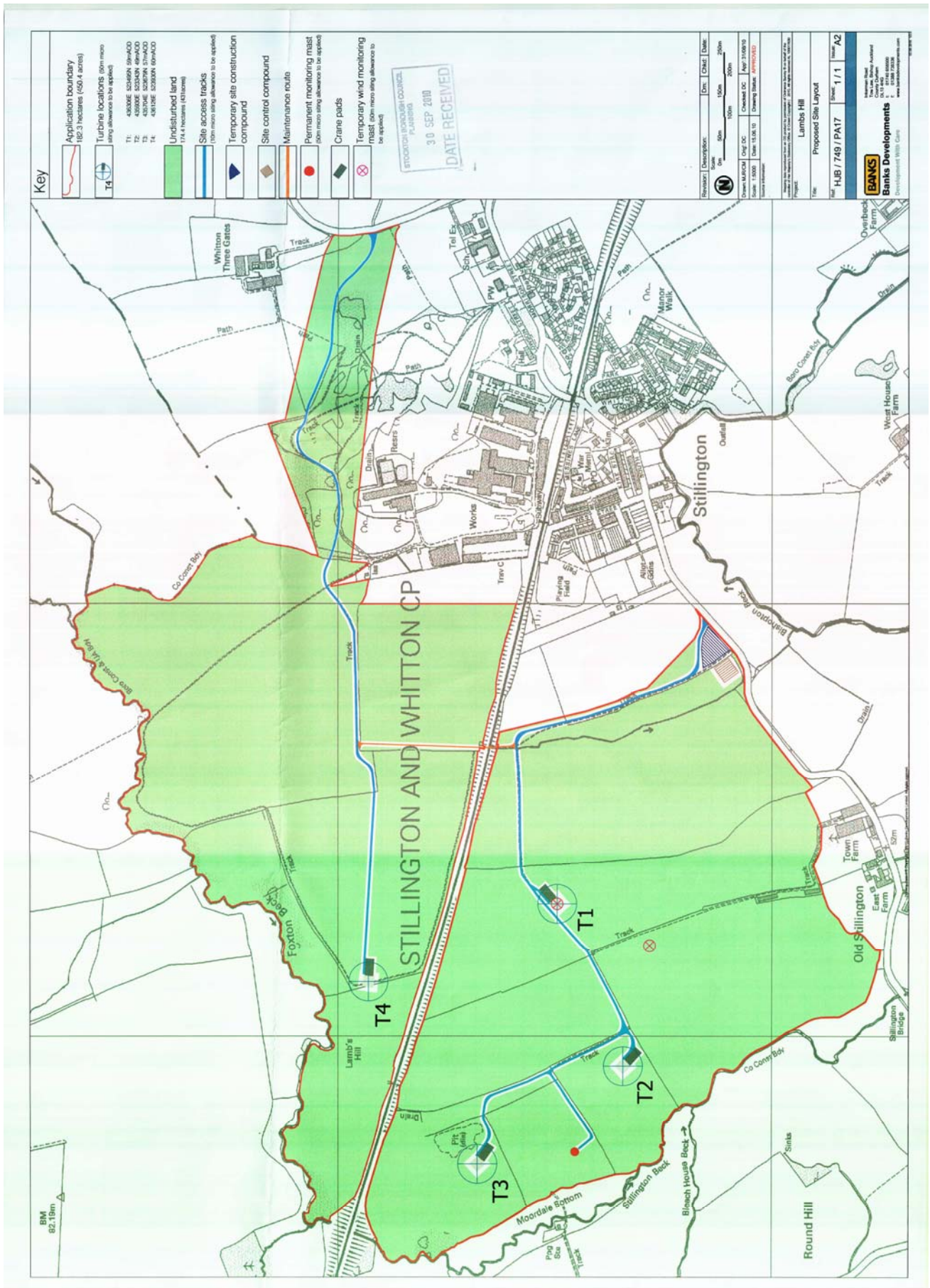

10/2549/EIS – Lambs Hill Wind Farm
Appendix reference 3
Typical Turbine Detail

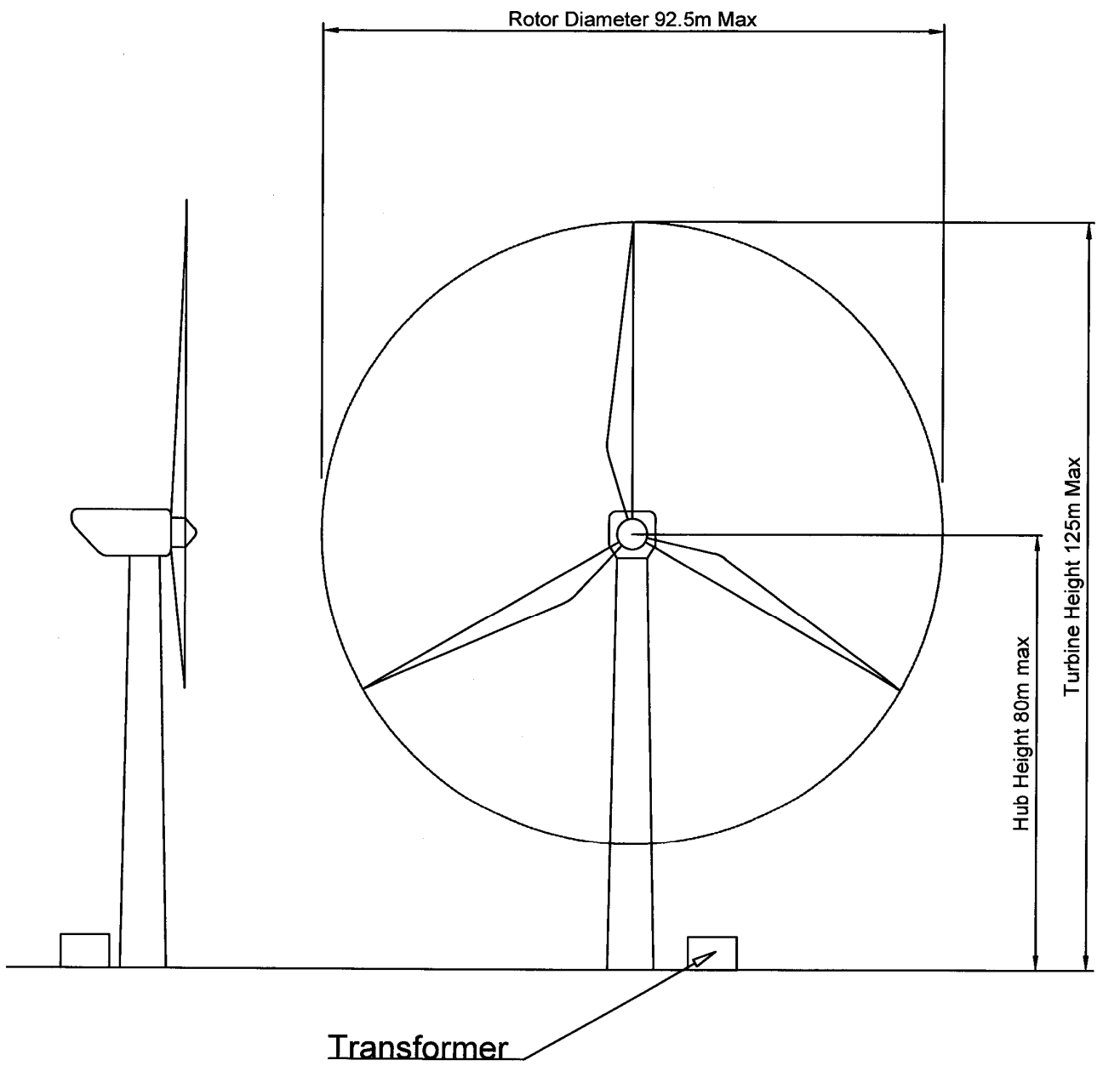

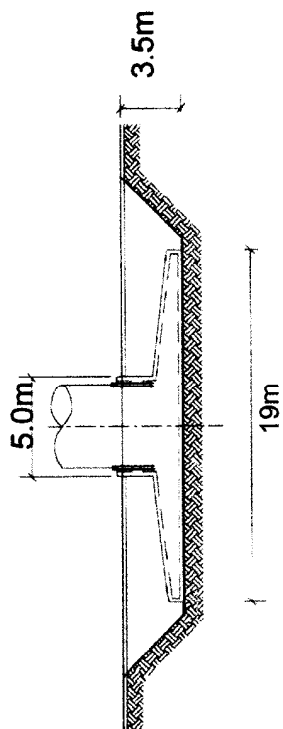

Typical gravity foundation
Turbine Foundation
Section View

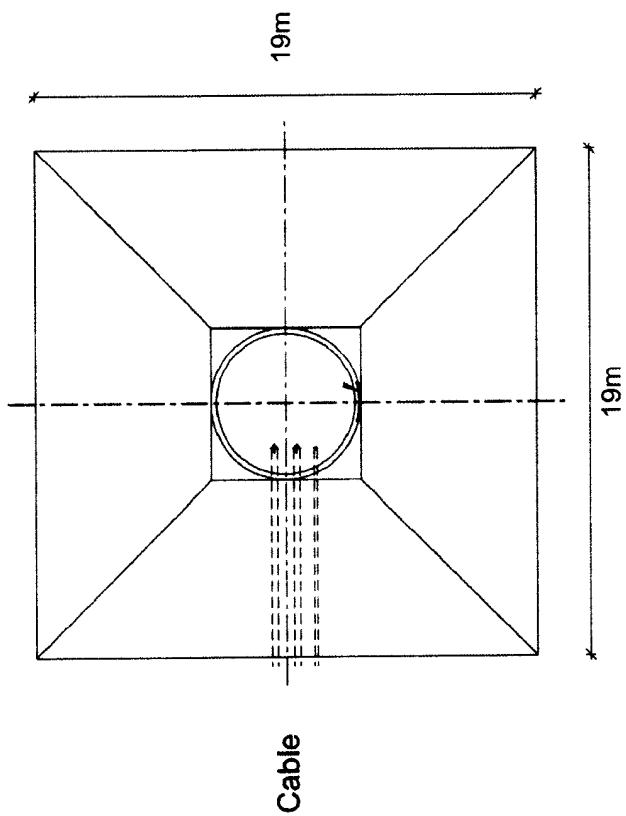

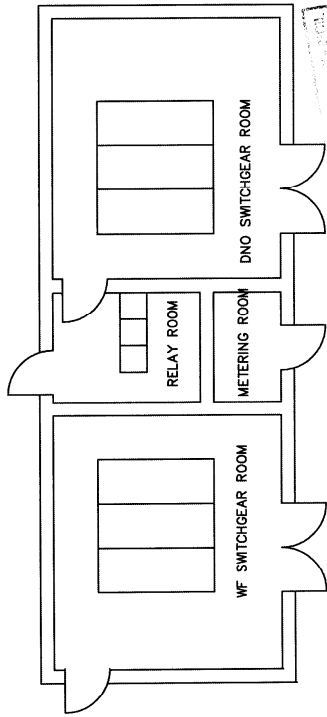

Turbine Foundation
Plan View

10/2549/EIS – Lambs Hill Wind Farm
 Appendix reference 5
 Typical Control Building

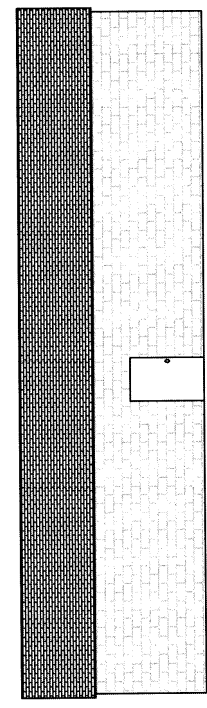
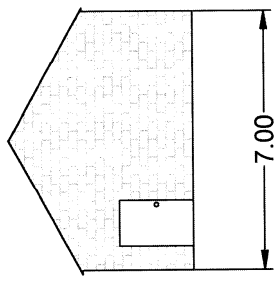
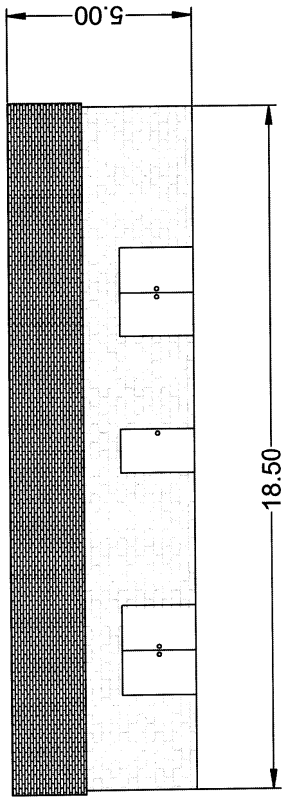

Approximately 18.5m x 7m x 5m in height
 External material to be agreed with local
 planning authority



Revision:	Description:	Dwn:	Chkd:	Date:
Drawn: SH	Checked: EK	App: 17/09/10		
Scale: 1:125	Date: 01/07/10	Drawing Status: APPROVED		
Source information				
Mapping data reproduced from: Buis: 10,000 by permission of Ordnance Survey, is on behalf of the controller of Her Majesty's Stationery Office, © Crown Copyright (2008). All rights reserved. N: 0007900				
Project: Lambs Hill				
Title: Typical Control Building Design				
Drawing number: HJUB / 749 / PA20 Rev: Issue A3				
 Banks Developments Development With Care Inkerman Road Tow. Lav. Bishop Auckland County Durham DL13 4JG T: 01749 665000 F: 01749 730306 www.banksdevelopments.com				

10/2549/EIS – Lambs Hill Wind Farm
Appendix reference 6
Possible grid connection corridor

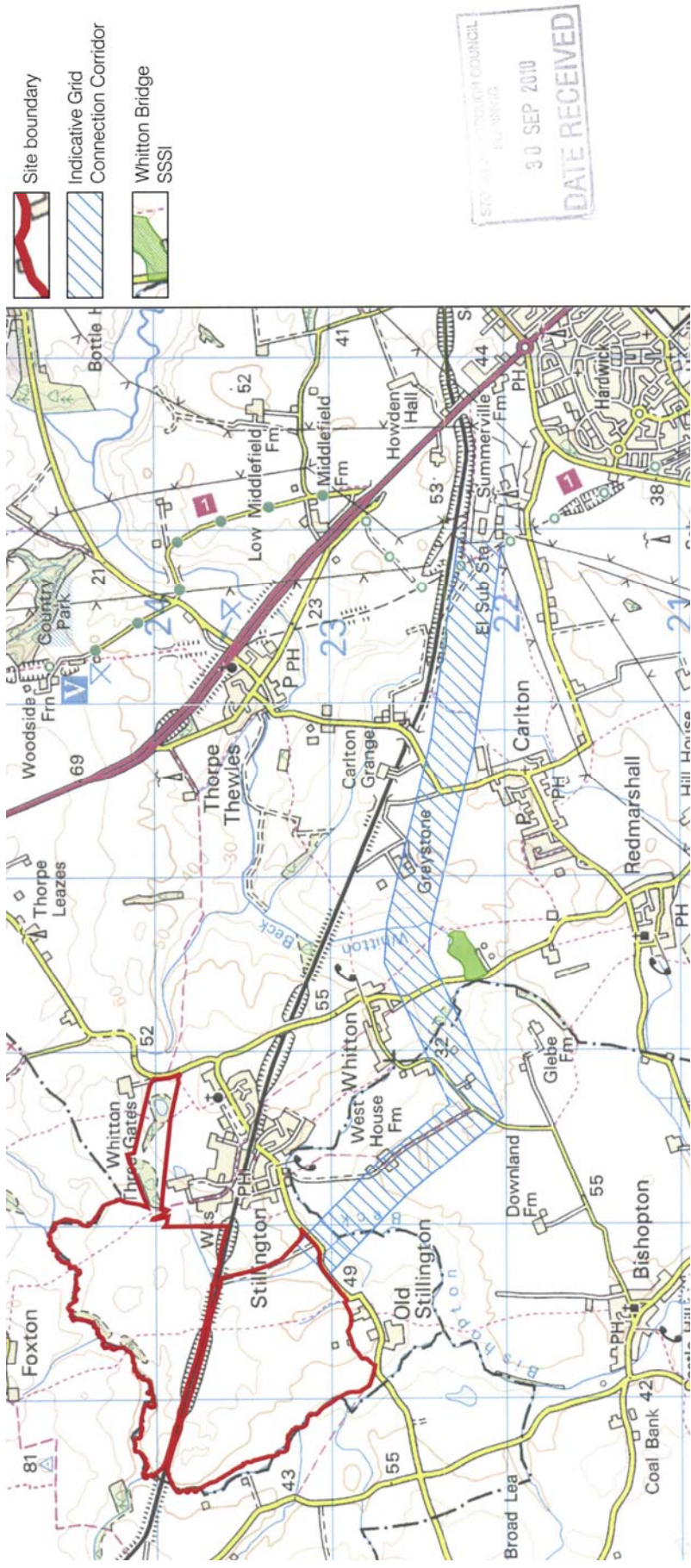

10/2549/EIS – Lambs Hill Wind Farm
 Appendix reference 7
 Indicative Lay down and Construction Compound Area

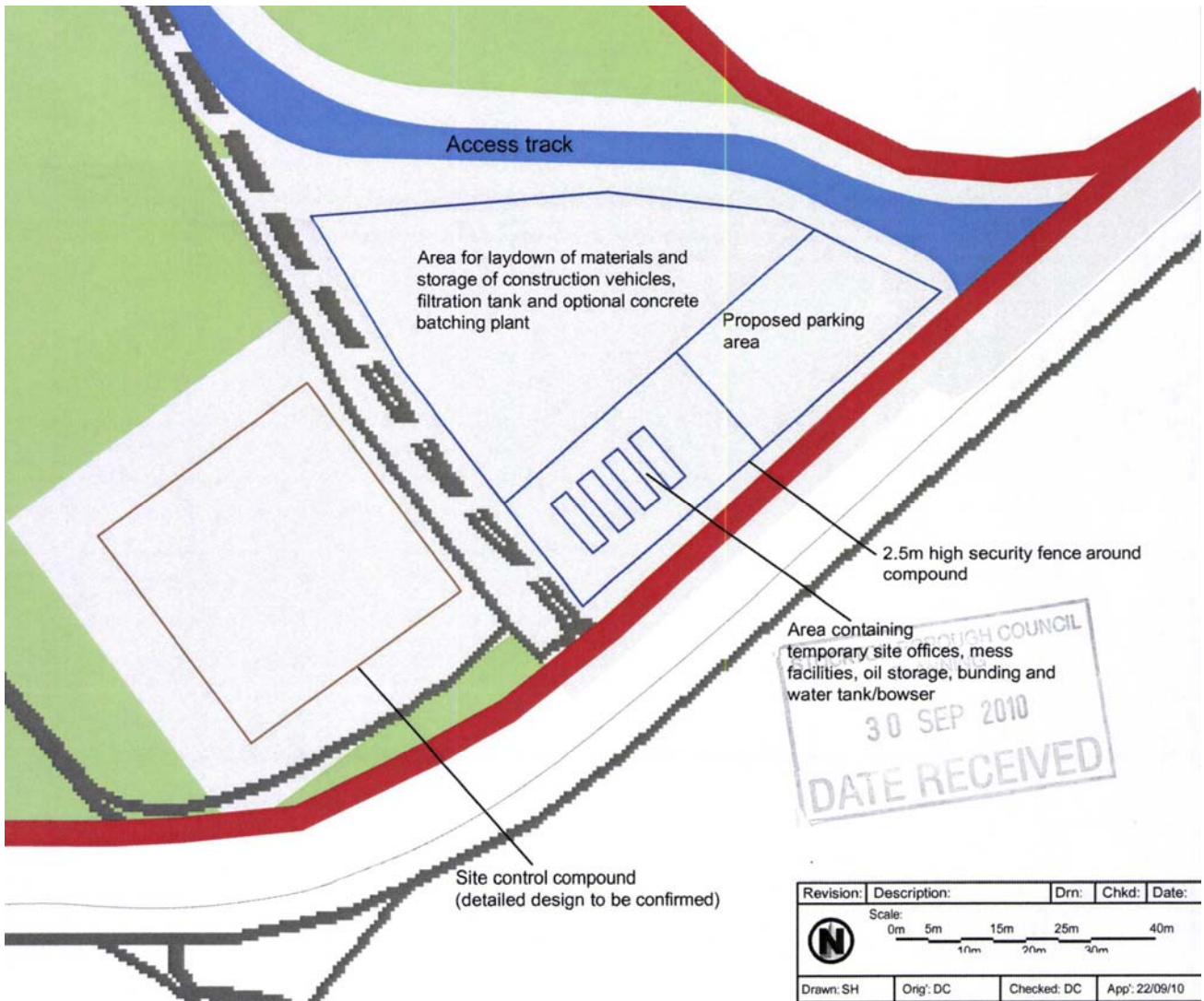

10/2549/EIS – Lambs Hill Wind Farm
Appendix reference 8
Cross sections of typical internal tracks

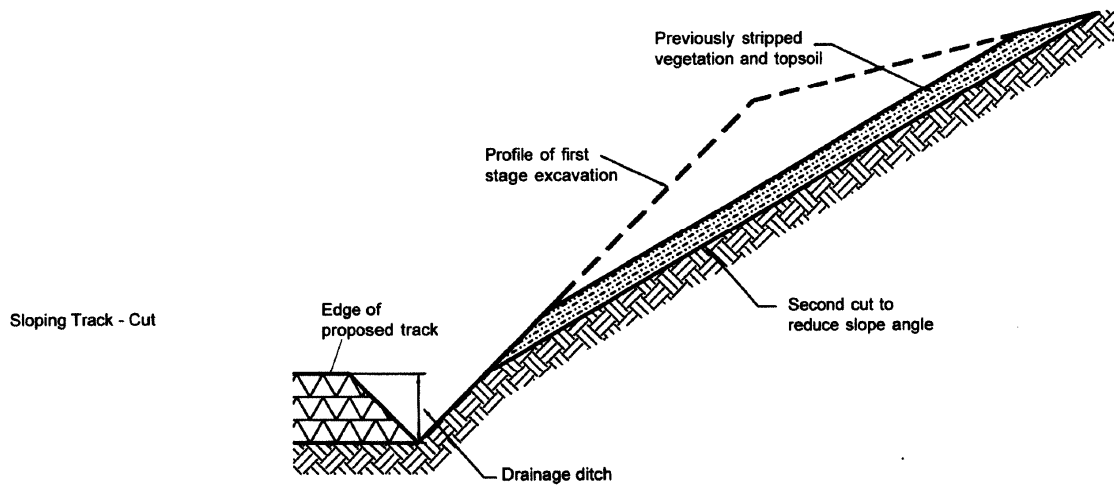
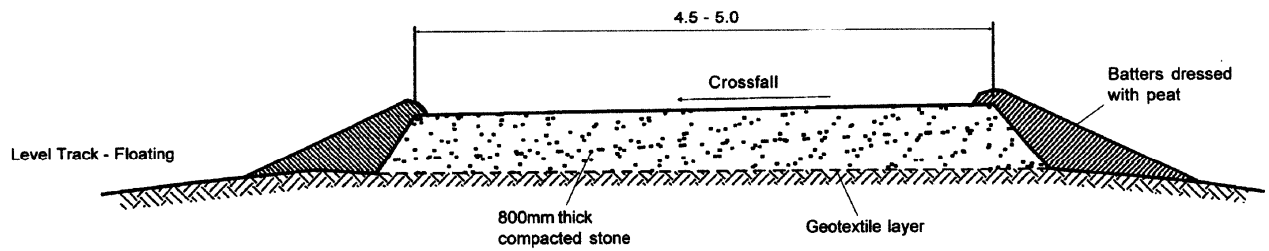
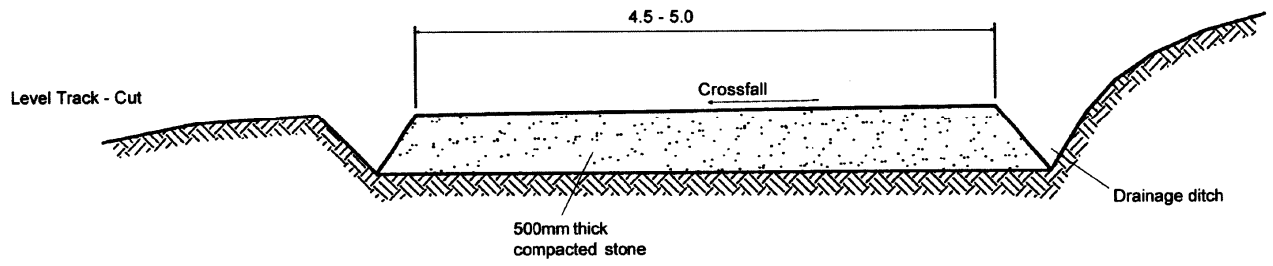

10/2549/EIS – Lambs Hill Wind Farm
Appendix reference 9
Typical 60m Met Mast

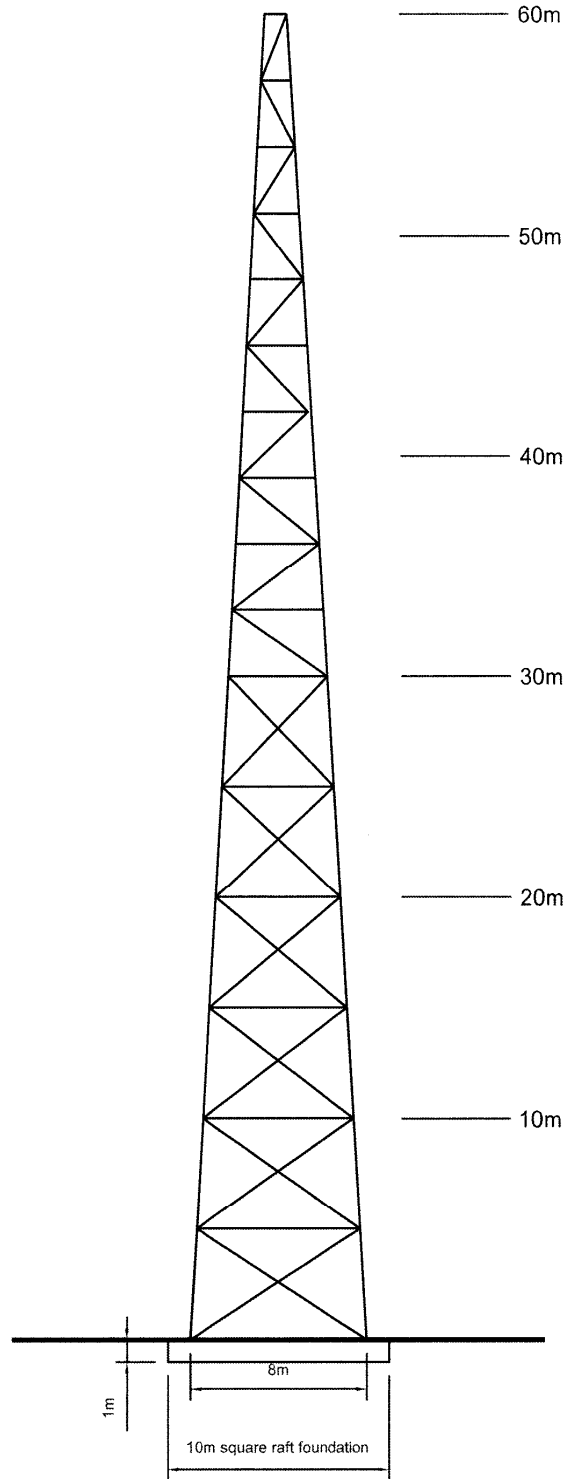

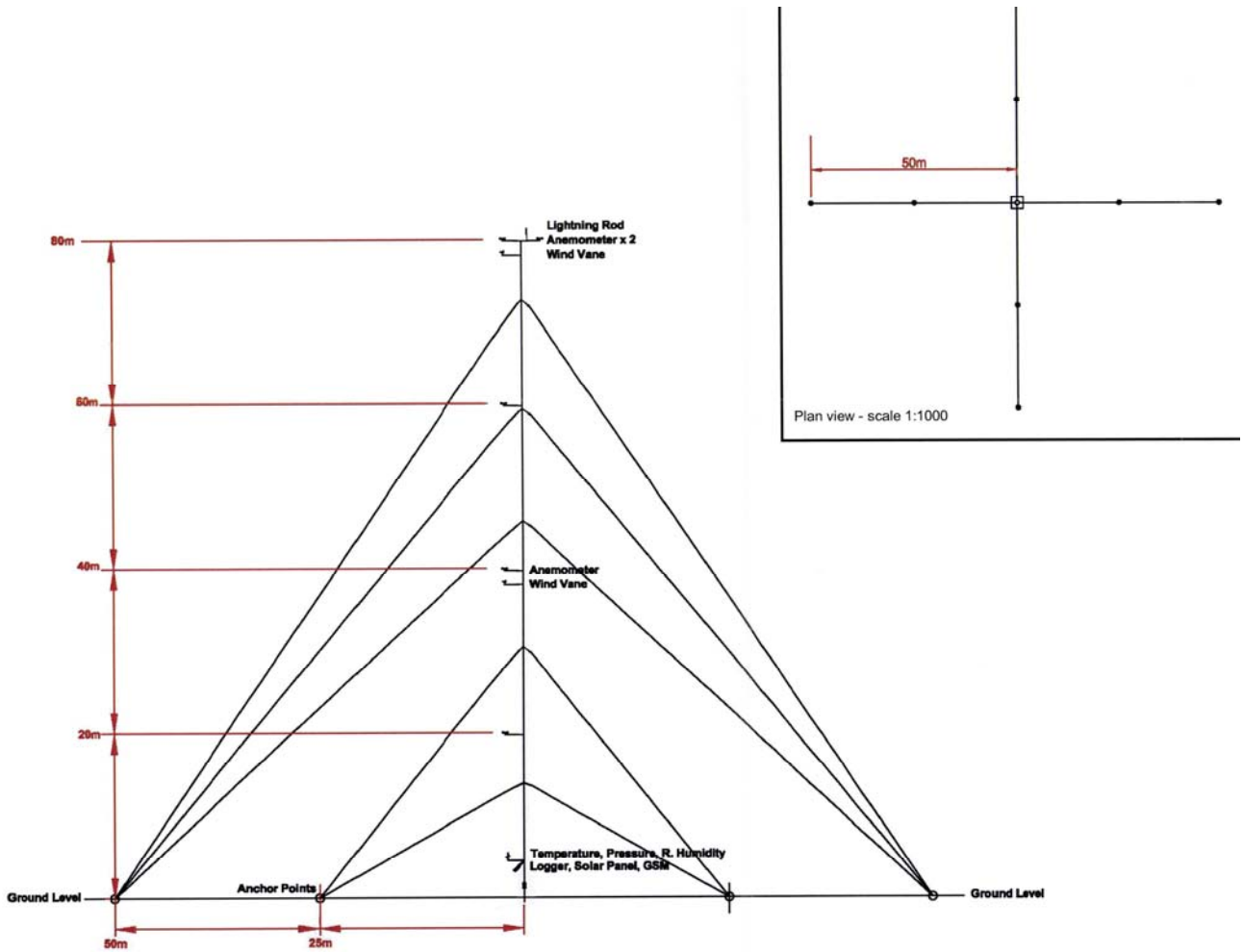

Typical 80m Meteorological Mast Arrangement

Wind Farm Development and Landscape Capacity studies – East Durham and Tees Plain
Addendum. Zoning Map and associated text.

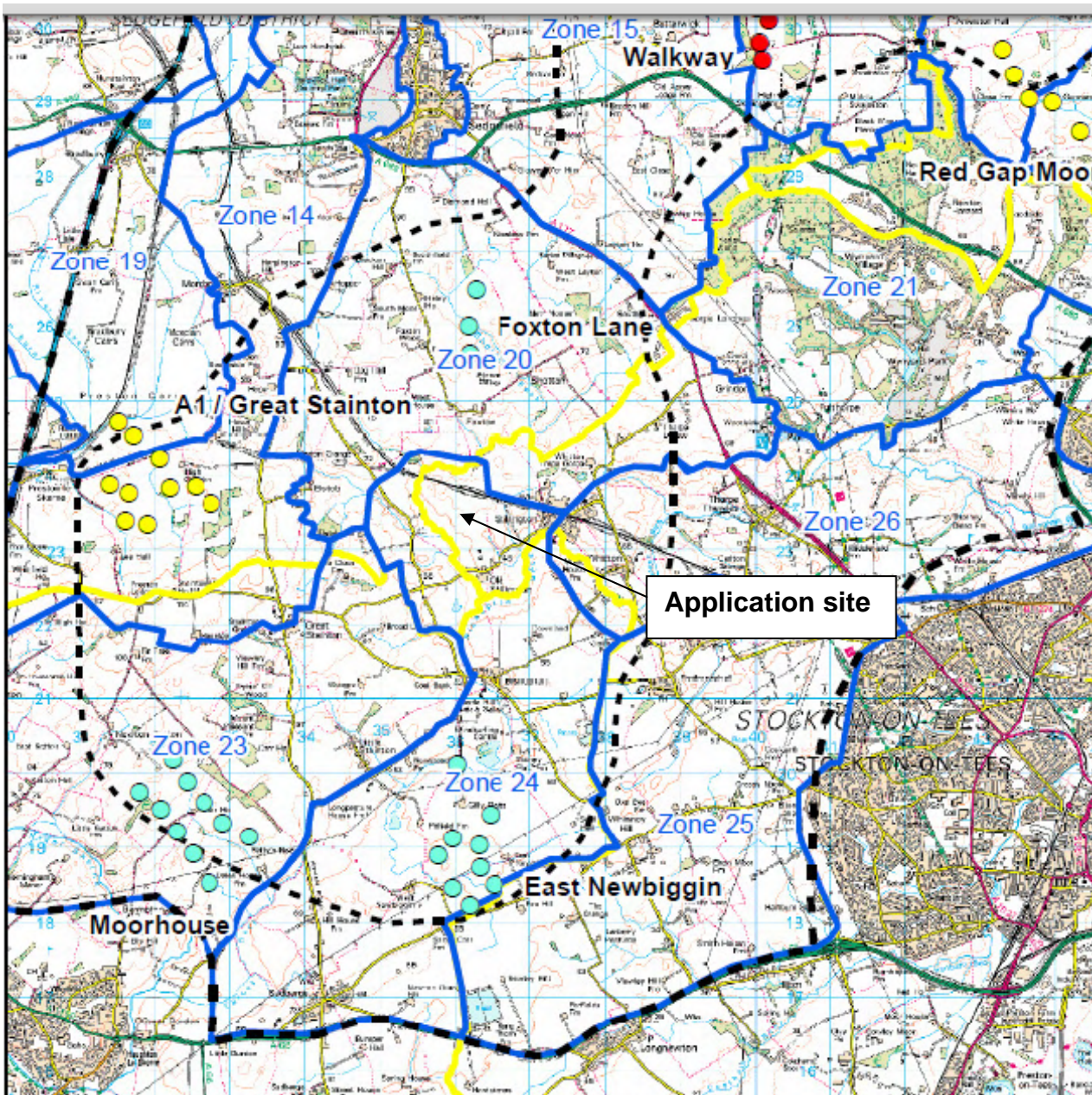

Moorhouse wind farm (Zone 23)

The proposed Moorhouse wind farm (referred to as wind farm or site B in the scenario assessment) comprises 10 turbines which are all located within Zone 23. The main study identified that the largest wind farm typology potentially acceptable in Zone 23 was small medium small, i.e. development of “between 7.5-18 MW or 4-6 turbines approx.” Overall the level of development proposed in this location exceeds the capacity of the landscape identified in the main study. However, the extent to which a development of the scale proposed would exceed the capacity of the local landscape, and the significance of that in the context of the policy environment at the time the application is determined, can only be fully resolved through a detailed investigation of the landscape and visual impacts of the individual scheme which is beyond the scope of this study. In terms of overall visibility within 15km Zone 23 was ranked 25th out of 27 Zones (where 1 was best and 27 worst). Zone 23 performed in the bottom 50% in terms of effects on settlements within 10km, in the top 50% in terms of effects on settlements with 2km and in the bottom 50% in terms of effects on roads up to 5km. Overall Zone 23 was ranked as 22nd out of 27. In the main study Zone 23 was identified as having some suitability for (further) wind farm development, based on a high level review of the availability of technically unconstrained land and cumulative visibility issues. All of the turbines associated with the proposed

Moorhouse development apart from two are located within the “Least impact” area identified in the main study.

East Newbiggin wind farm (Zone 24)

The proposed East Newbiggin wind farm (referred to as wind farm or site C in the scenario assessment) comprises 9 turbines which are all located within Zone 24. The main study identified that the largest wind farm typology potentially acceptable in Zone 24 was small medium small, i.e. development of “between 7.5-18 MW or 4-6 turbines approx.” Overall the level of development proposed in this location exceeds the capacity of the landscape identified in the main study. However, the extent to which a development of the scale proposed would exceed the capacity of the local landscape, and the significance of that in the context of the policy environment at the time the application is determined, can only be fully resolved through a detailed investigation of the landscape and visual impacts of the individual scheme which is beyond the scope of this study.

Foxton Lane wind farm (Zone 20)

The proposed Foxton wind farm (referred to as wind farm or site D in the scenario assessment) comprises 3 turbines which are all located within Zone 20. The main study identified that the largest wind farm typology potentially acceptable in Zone 20 was medium small, i.e. development of “between 7.5-25 MW or 4-9 turbines approx.” The level of development proposed in this location is below the capacity of the landscape identified in the main study. In terms of overall visibility within 15km Zone 20 was ranked 22nd = out of 27 Zones (where 1 was best and 27 worst). Zone 20 performed in the bottom 50% in terms of effects on settlements within 10km, but in the top 25% in terms of effects on settlements with 2km and in the top 50% in terms of effects on roads up to 5km. Overall Zone 20 was ranked as 10th out of 27. In the main study Zone 20 was identified as having some suitability for (further) wind farm development, based on a high level review of the availability of technically unconstrained land and cumulative visibility issues. The proposed Foxton Lane wind farm is located entirely within the “Least impact” area identified in the main study.

Extracts from Page 11 of the Association of North East Councils document ‘Wind Farm Development and Landscape Capacity Studies – East Durham and Tees Plain Addendum Oct 2009.

Extract taken from ES appendix ref 6.1. Proximity to Public Rights of Way

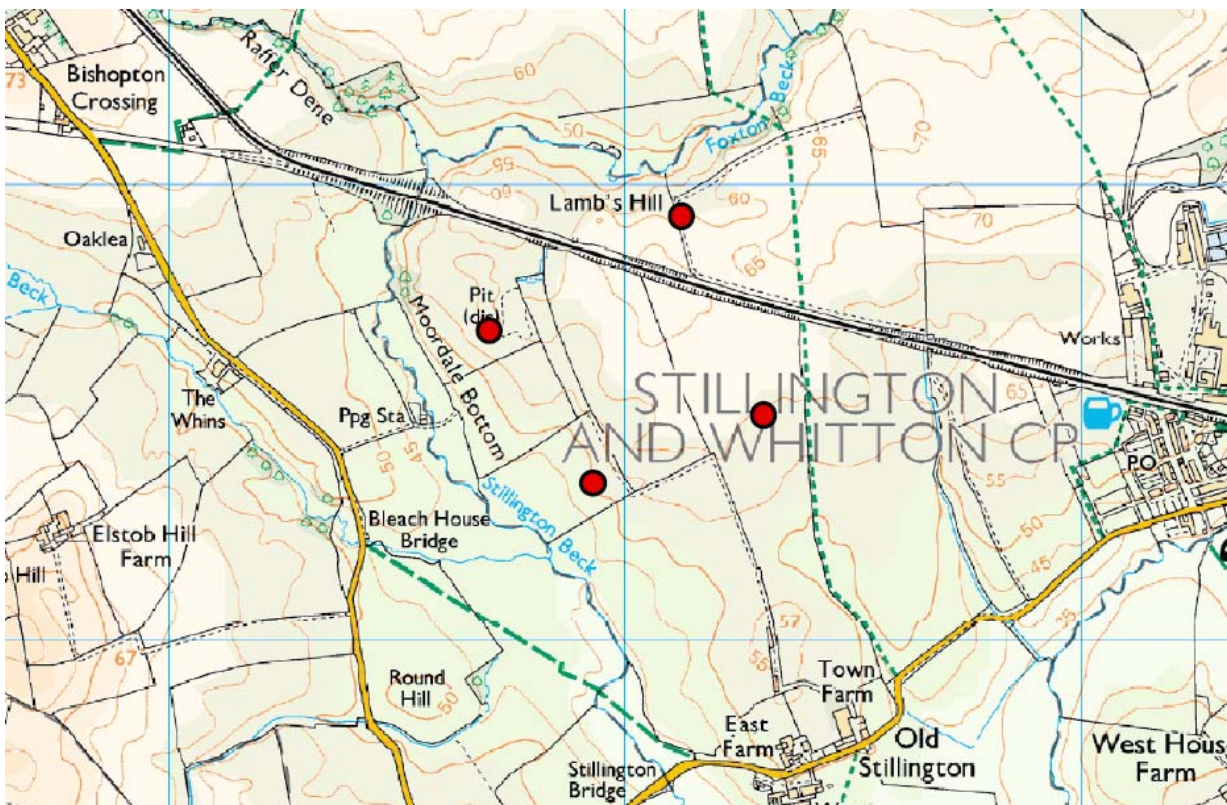
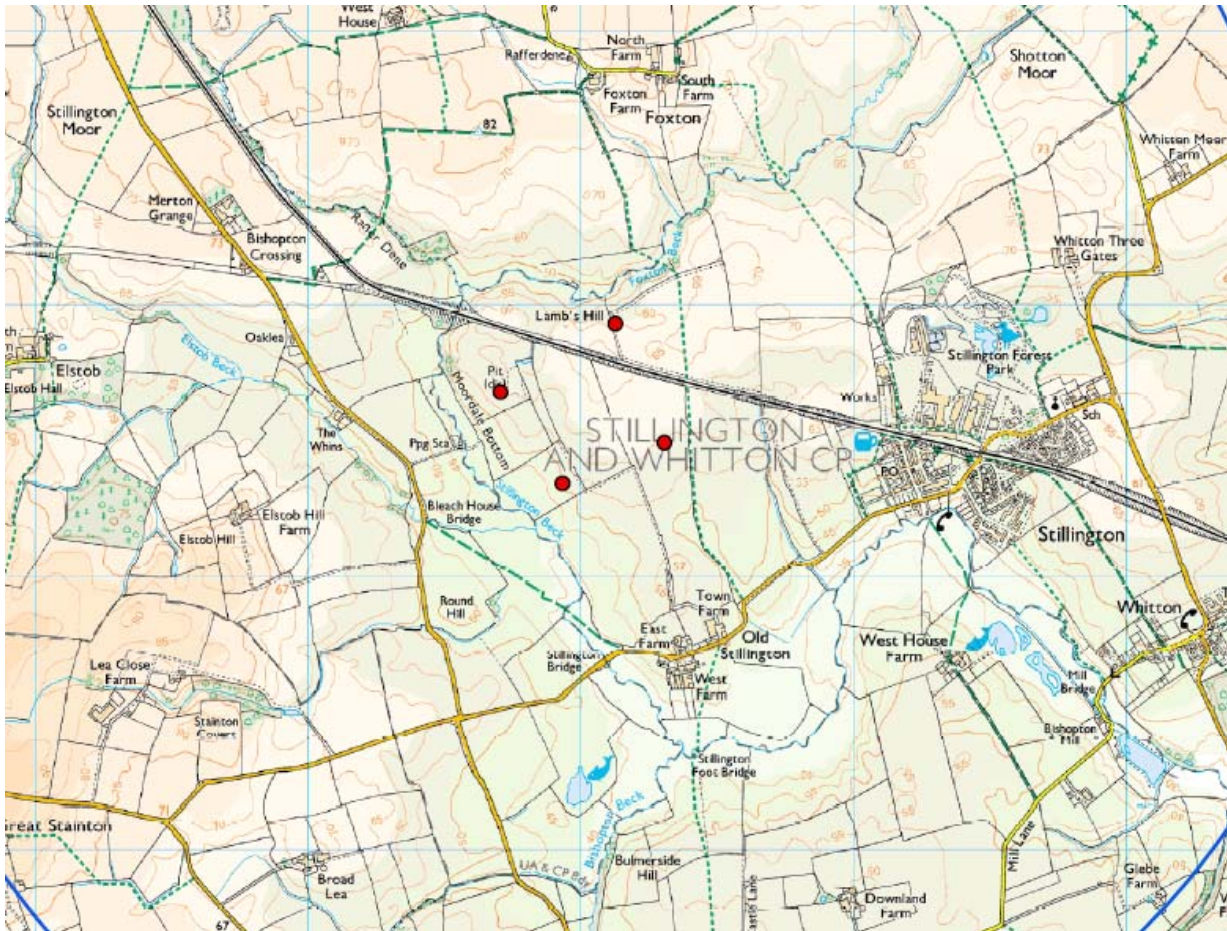

10/2549/EIS – Lambs Hill Wind Farm
Appendix reference 13
Access Track Route Through Forest Park

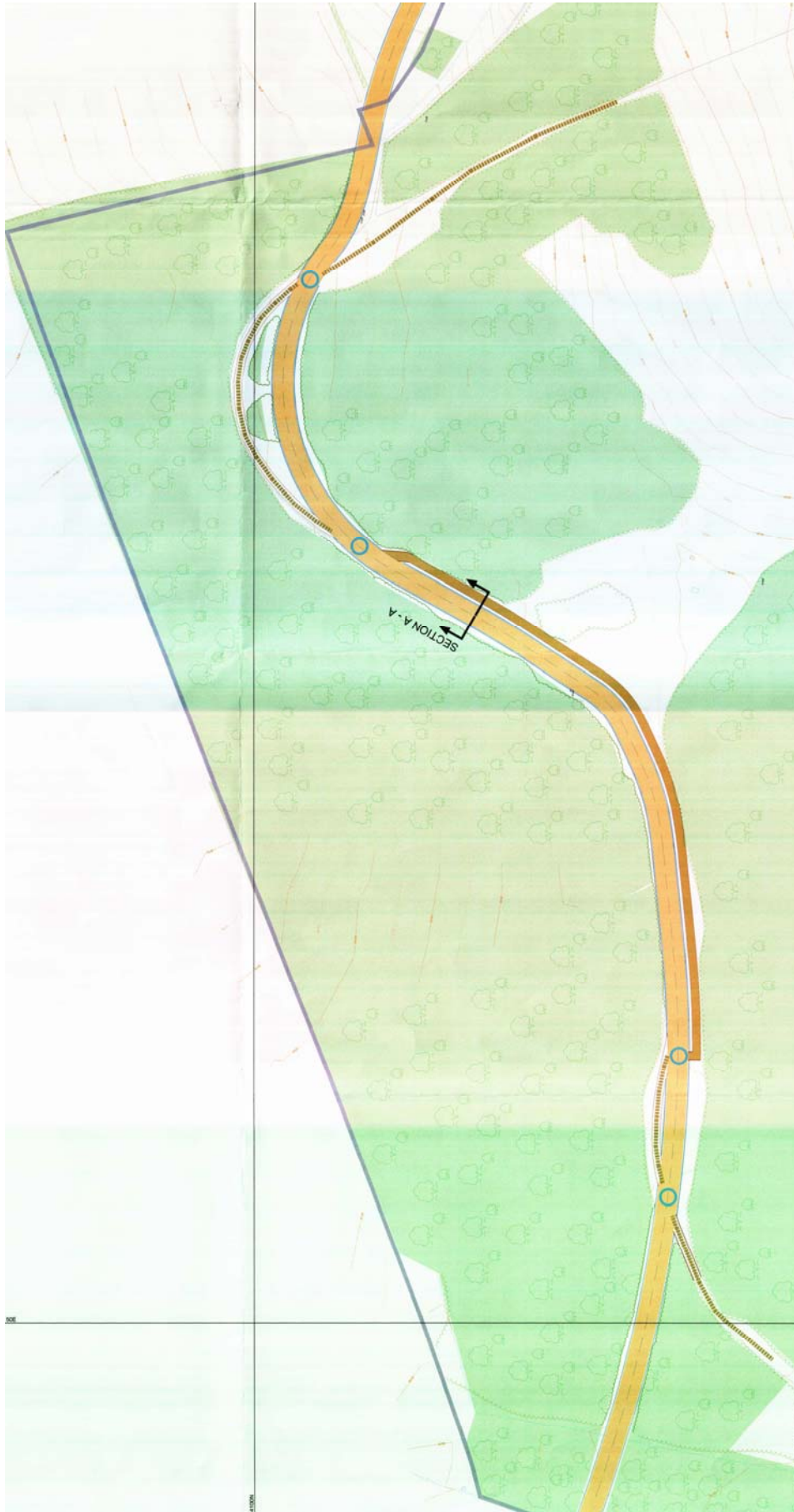

10/2549/EIS – Lambs Hill Wind Farm

Appendix reference 14

Map showing cumulative turbine locations

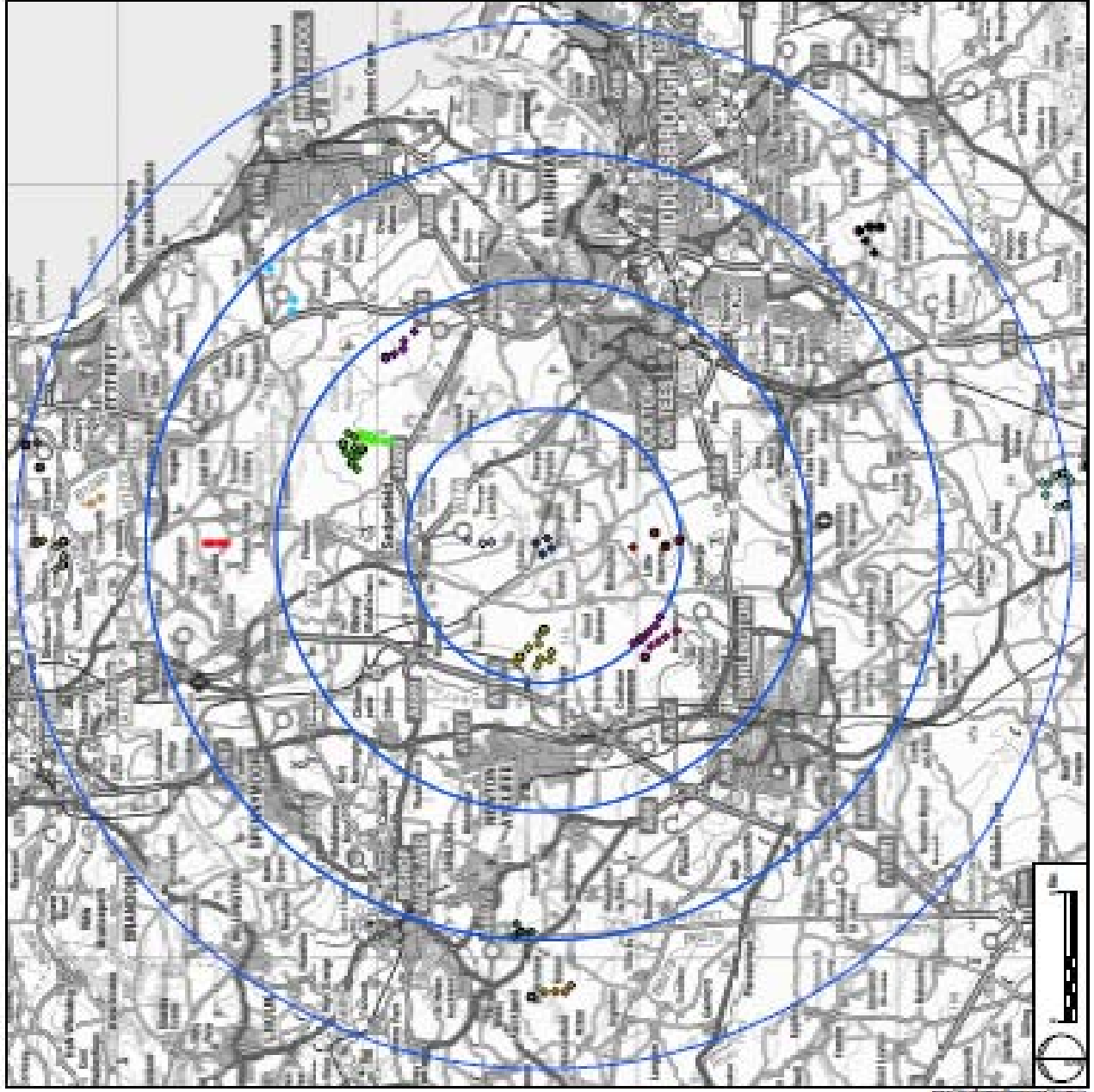

10/2549/EIS – Lambs Hill Wind Farm
Appendix reference 15
Heavy goods Vehicle Routing Plan

